

### ⚠ DANGER

- Arc flash and shock hazard. Appropriate PPE required. Failure to wear appropriate PPE will result in death or serious injury.

### ⚠ WARNING

- Read and follow all instructions carefully.
- Disconnect and lock out power before installation and maintenance. Working on or near energized equipment can result in severe injury or death.
- Do not operate equipment without guards in place. Exposed equipment can result in severe injury or death.

### ⚠ CAUTION

- Periodic inspections should be performed. Failure to perform proper maintenance can result in premature product failure and personal injury.

### NOTICE

- Do not pry or otherwise force belts onto sheave. Doing so may result in permanent damage to the belt.

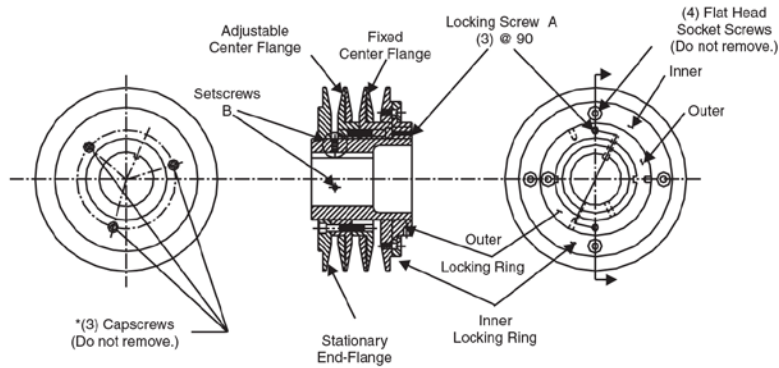

**Straight Bore Sheave**

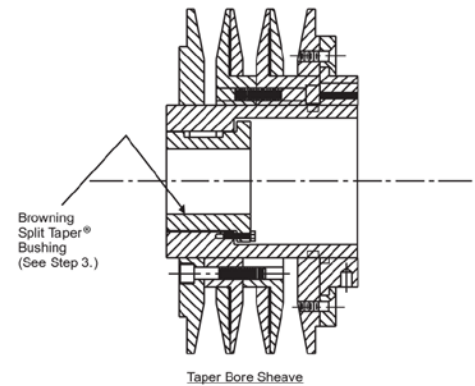
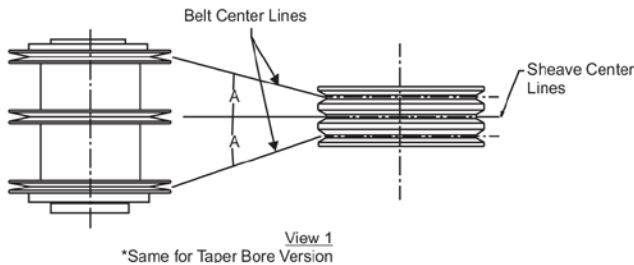

### Mounting:

1. Make sure the shaft, sheave bore, keys and keyways are free of burrs, paint, etc.
2. All straight bore sheaves should be mounted on the motor or driving shaft with the end containing set screws "B" toward the motor. Sheave should be located as close to the motor as possible with the set screws "B" in full contact with the key and shaft. The shaft key is provided with the sheave on some sizes.
3. If the sheave has a tapered bore to accommodate a Browning Split Taper® Bushing, follow the instructions on the split taper bushing box, or refer to Regal Form No. 4013 (Browning Split Taper bushing instructions).
4. Be sure both driving and driven sheaves are in alignment and that shafts are parallel. The centerline of the driving sheave must line up with the centerline of the driven sheave. Angle "A" cannot exceed 1/2° for raw edge belts and 2° for wrapped belts. See View 1.
5. For straight bore sheaves, tighten set screws "B" in place.
6. Be sure that all setscrews and capscrews are torqued to values shown in Table A with a torque wrench before starting drive. Check setscrew torque and belt tension after 24 hours service. See Table A. Refer to Regal® Browning® Components Catalog, "Tensioning V-Belt Drives," or Regal Form No. 5453 (Belt Tension Checker) for tensioning instructions.



**Adjusting:**

7. Slack off all belt tension by moving motor toward the driven shaft until belts are free of grooves. For easiest adjustment, remove the belts from the grooves.
8. Loosen, but don't remove the three locking set screws "A" in outer locking ring, by using a hex key or torque wrench with hex bit (key).
9. Adjust sheave to desired pitch diameter by turning the outer locking ring. Three holes 120° apart are provided for a spanner wrench or drift for ease of turning.
10. Any pitch diameter can be obtained within the sheave range. One complete turn of the outer locking ring will result in a .233" change in pitch diameter.
11. Opening sheaves more than shown below may lead to poor sheave and belt performance.  
 Do not open "B" sheaves more than 4-3/4 turns for "A" belts or 6 turns for "B" belts.  
 Do not open "C" sheaves more than 9-1/2 turns.  
 Do not open "D" sheaves more than 13 turns.  
 Do not open "5V" sheaves more than 6 turns.  
 Do not open "8V" sheaves more than 8-1/2 turns.
12. Tighten all three locking screws "A" in the outer locking ring to the value shown in Table A with a torque wrench and hex bit (key).
13. Replace belts and move motor away from driven shaft to tension belts properly. Refer to Regal® Browning® Components Catalog, "Tensioning V-Belt Drives", or Regal Form No. 5453 (Belt Tension Checker) for tensioning instructions. Check speed. If further adjustment is needed, repeat the steps 7-12 above.
14. Do not loosen any screws other than the three locking screws "A" in the outer locking ring. These screws should be loosened only while the drive is at rest and adjustment is being made. Locking screws "A" must be tightened before drive is operated after adjustment.

**CAUTION:** Tighten locking screws "A" to value shown with a torque wrench and hex bit (key). Otherwise locking ring and flange may come off the assembly during operation.

15. Field disassembly of sheave is not recommended. If it is felt that complete disassembly is necessary, please contact application engineering at 1-800-626-2093.

**Table A**

Nominal screw size (Dia.-Threads/In)	SocketHead Capscrews		FlatHead Socketscrews	Hollow Head Setscrews Only			
				For Lengths Equal to or Greater than Diameter		For Lengths (L) Less than Diameter	
	Seating Torque		Seating Torque	Seating Torque	Seating Torque	Length (L)	Seating Torque
	(In. - Lbs.)	(Ft. - Lbs.)	(In. - Lbs.)	(In. - Lbs.)	(Ft. - Lbs.)	(In.)	(Ft. - Lbs.)
1/4 - 20NC	150	12.5	100	87	7.3	3/16	50
5/16 - 18NC	305	25.4	200	165	13.8	1/4	90
3/8 - 16NC	545	45.4	350	290	24.2	1/4 - 5/16	150 - 250
1/2 - 13NC	1300	108.3	n/a	620	51.7	n/a	n/a
5/8 - 11NC	n/a	n/a	n/a	1225	102.1	n/a	n/a

